

## TEGA IPS SERIES SDR26

ELECTROFUSION COUPLER, DUAL RATED WATER/NATURAL GAS  
**Water - 100 PSI** at 73 Deg F Sustainable Maximum Operating Pressure  
**Gas - 60 PSI** at 73 Deg F Sustainable Maximum Operating Pressure  
 Suitable for Water, Fluids & Slurry's

Engineered for PE3408, PE4710 & PE100 HDPE Pipe Systems  
 Manufactured in accordance with ASTM F-714, ASTM F-1055, ASTM D-2513  
 ASTM D-3035, ASTM D-3261, ASTM D-3350, AWWA C-901, AWWA C-906  
 DIN16963, EN1555, EN12201, ISO-9001/2000

**Also suitable for use on IPS SDR32.5 Series HDPE pipe**

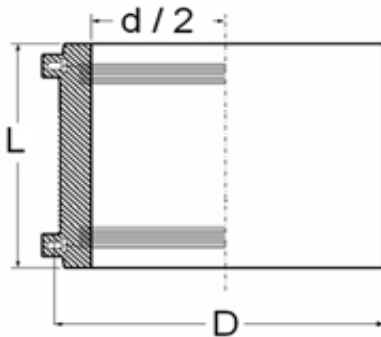

Style "A"



Style "A"

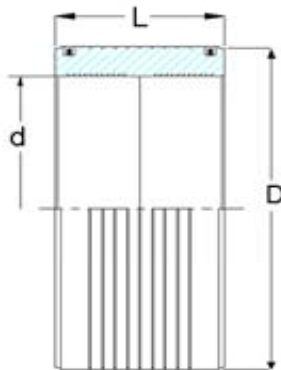

Style "B"



Style "B"

Nominal Pipe						
Size	"d & d/2"	"D"	"L"	Unit Weight	Style	Item Code
4"	4.500"	4.920"	3.940"	0.430 lbs	A	30.MA1.11.27.0114
5"	5.563"	6.100"	6.300"	1.080 lbs	B	30.MA1.11.27.0141
6"	6.675"	7.480"	6.300"	1.950 lbs	B	30.MA1.11.27.0169
7"	7.125"	7.750"	6.300"	1.620 lbs	B	30.MA1.11.27.0180
8"	8.625"	9.650"	6.500"	3.300 lbs	B	30.MA1.11.27.0219
10"	10.750"	12.010"	6.500"	5.060 lbs	B	30.MA1.11.27.0273

12"	12.750"	14.560"	6.500"	8.780 lbs	B	30.MA1.11.27.0323
14"	14.000"	15.350"	7.090"	7.670 lbs	B	30.MA1.11.27.0355
16"	16.000"	18.500"	8.660"	20.370 lbs	B	30.MA1.11.27.0406
18"	18.000"	20.470"	8.660"	22.430 lbs	B	30.MA1.11.27.0457
20"	20.000"	22.440"	9.450"	26.650 lbs	B	30.MA1.11.27.0508
22"	22.000"	24.210"	9.840"	27.400 lbs	B	30.MA1.11.27.0558
24"	24.000"	26.770"	13.780"	52.790 lbs	B	30.MA1.11.27.0609
26"	26.000"	28.740"	13.780"	56.270 lbs	B	30.MA1.11.27.0660
28"	28.000"	30.710"	13.780"	59.660 lbs	B	30.MA1.11.27.0711
30"	30.000"	33.070"	13.780"	72.660 lbs	B	30.MA1.11.27.0762
32"	32.000"	35.430"	13.780"	86.850 lbs	B	30.MA1.11.27.0812
34"	34.000"	37.400"	15.750"	104.130 lbs	B	30.MA1.11.27.0863
36"	36.000"	40.550"	19.690"	186.720 lbs	B	30.MA1.11.27.0914
42"	42.000"	46.460"	19.690"	211.280 lbs	B	30.MA1.11.27.1066
48"	48.000"	53.150"	19.690"	279.160 lbs	B	30.MA1.11.27.1219
54"	54.000"	59.060"	19.690"	306.290 lbs	B	30.MA1.11.27.1371
63"	63.000"	68.900"	19.690"	416.890 lbs	B	30.MA1.11.27.1600

**Reducing Couplers In This Series Available Under Special Request**

**STRONGBRIDGE INTERNATIONAL INC.**

10920 Baymeadows Road, Unit 27-302  
 Jacksonville, FL 32256  
 Phone: (904) 607-6384 Fax:(904) 565-2776  
[www.strongbridge.us](http://www.strongbridge.us)

**STRONGBRIDGE INTERNATIONAL (CANADA) INC.**

200 North Service Road West, Unit 1 Suite 381  
 Oakville, Ontario L6M 2Y1  
 Phone (416) 795-8962  
[www.strongbridgecanada.com](http://www.strongbridgecanada.com)

**TEGA ELECTROFUSION FITTINGS MAY ONLY BE INSTALLED BY TECHICIANS CERTIFIED BY STRONGBRIDGE INTERNATIONAL INC. OR ITS DESIGNATED AND APPROVED AGENTS. CONTACT STRONGBRIDGE INTERNATIONAL FOR CURRENT CERTIFICATION DETAILS AND REQUIREMENTS.**

Copyright 2009 Strongbridge International Inc. All rights reserved. Information subject to change without notice. E. & O.E.  
 Subject to Strongbridge International Inc. Limited Warranty, available at [www.strongbridge.us](http://www.strongbridge.us)