

TEGA IPS SERIES SDR11

ELECTROFUSION COUPLER, DUAL RATED WATER/NATURAL GAS

Water - 200-240 PSI at 73 Deg F Sustainable Maximum Operating Pressure

Gas - 150 PSI at 73 Deg F Sustainable Maximum Operating Pressure

Suitable for Water, Fluids & Slurry's

Engineered for PE3408, PE4710 & PE100 HDPE Pipe Systems

Manufactured in accordance with ASTM F-714, ASTM F-1055, ASTM D-2513

ASTM D-3035, ASTM D-3261, ASTM D-3350, AWWA C-901, AWWA C-906

DIN16963, EN1555, EN12201, ISO-9001/2000

Also suitable for use on IPS SDR13.5, SDR15.5, SDR17 Series HDPE pipe

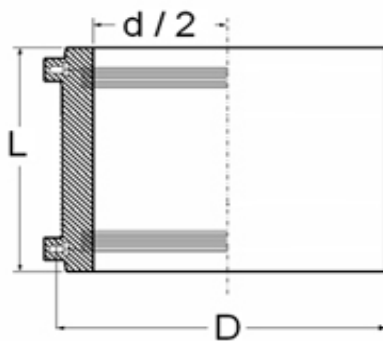

Style "A"



Style "A"

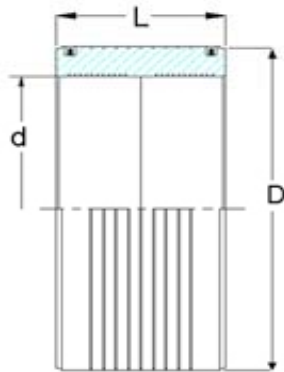

Style "B"



Style "B"

Nominal Pipe Size	"d & d/2"	"D"	"L"	Unit Weight	Style	Item Code	Note
1/2"	0.840"	1.610"	2.800"	0.060 lbs	A	30.MA1.11.11.0021	
3/4"	1.050"	1.610"	2.800"	0.110 lbs	A	30.MA1.11.11.0026	
1"	1.315"	1.890"	3.230"	0.160 lbs	A	30.MA1.11.11.0033	
1 1/4"	1.660"	2.170"	3.390"	0.180 lbs	A	30.MA1.11.11.0042	
1 1/2"	1.900"	2.640"	3.860"	0.350 lbs	A	30.MA1.11.11.0048	
2"	2.375"	3.150"	4.210"	0.490 lbs	A	30.MA1.11.11.0060	
2 1/2"	2.875"	3.820"	4.645"	0.770 lbs	A	30.MA1.11.11.0073	
3"	3.500"	4.530"	5.910"	1.330 lbs	A	30.MA1.11.11.0088	

4"	4.500"	5.590"	6.690"	1.860 lbs	A	30.MA1.11.11.0114	
5"	5.563"	7.090"	6.730"	3.530 lbs	A	30.MA1.11.11.0141	
6"	6.675"	8.070"	7.280"	5.510 lbs	A	30.MA1.11.11.0169	
7"	7.125"	9.060"	7.560"	5.650 lbs	A	30.MA1.11.11.0180	
8"	8.625"	10.830"	8.030"	8.990 lbs	A	30.MA1.11.11.0219	*
10"	10.750"	13.580"	8.660"	14.990 lbs	B	30.MA1.11.11.0273	
12"	12.750"	15.550"	9.060"	19.530 lbs	B	30.MA1.11.11.0323	*
14"	14.000"	17.520"	10.000"	29.130 lbs	B	30.MA1.11.11.0355	
16"	16.000"	19.490"	11.810"	39.810 lbs	B	30.MA1.11.11.0406	*
18"	18.000"	21.810"	12.600"	52.040 lbs	B	30.MA1.11.11.0457	*
20"	20.000"	24.210"	14.410"	73.070 lbs	B	30.MA1.11.11.0508	*
22"	22.000"	27.170"	15.750"	108.880 lbs	B	30.MA1.11.11.0558	*
24"	24.000"	29.720"	15.750"	131.860 lbs	B	30.MA1.11.11.0609	
26"	26.000"	32.280"	17.320"	132.720 lbs	B	30.MA1.11.11.0660	**
28"	28.000"	34.650"	17.520"	198.580 lbs	B	30.MA1.11.11.0711	**
30"	30.000"	37.010"	17.520"	223.980 lbs	B	30.MA1.11.11.0762	*
32"	32.000"	39.170"	18.500"	257.200 lbs	B	30.MA1.11.11.0812	*
34"	34.000"	42.130"	19.690"	318.260 lbs	B	30.MA1.11.11.0863	
36"	36.000"	44.090"	19.690"	310.570 lbs	B	30.MA1.11.11.0914	*
42"	42.000"	51.180"	19.690"	456.000 lbs	B	30.MA1.11.11.1066	*

These couplers can be fused to SDR9 pipe by using Special Bar Code. Contact Strongbridge before fusing to SDR9 pipe Reducing Couplers In This Series Available Under Special Request

*** 200 psi (240 psi under special order)**

**** 220 psi (240 psi under special order)**

STRONGBRIDGE INTERNATIONAL INC.

PO Box 58177, Jacksonville FL 32241
 Phone: (904) 607-6384 Fax:(904) 565-2776
www.strongbridge.us

STRONGBRIDGE INTERNATIONAL (CANADA) INC.

200 North Service Road West, Unit 1 Suite 381
 Oakville, Ontario L6M 2Y1
 Phone (416) 795-8962
www.strongbridgecanada.com

ELECTROFUSION FITTINGS MUST BE INSTALLED BY QUALIFIED INDIVIDUALS TRAINED AND CERTIFIED IN ELECTROFUSION INSTALLATION PROCEDURES.

Copyright 2009 Strongbridge International Inc. All rights reserved. Information subject to change without notice. E. & O.E.
 Subject to Strongbridge International Inc. Limited Warranty, available at www.strongbridge.us